

120X120X38 mm

KA1238-1N Series



- **Motor** : Two-pole shaded pole induction motor
- **Frame** : Aluminum Alloy, Painted black
- **Impeller** : Retardant thermoplastic in black color, rated UL94V-0
- **Speed Range** : $\pm 10\%$
- **Impedance protected**

SPECIFICATIONS

Model	Bearing	Nominal Voltage (V)	Frequency (Hz)	Air Flow (CFM)	Static Pressure (inchH ₂ O)	Speed (R.P.M.)	Nominal Current (Amp)	Input Power (Watt)	Noise (dBA)	Weight (g)
KA1238H1-1N	B, S	110-120	50	97	0.284	2600	0.30	21	42	520
			60	109	0.285	2900		18	45	
KA1238M1-1N	B, S		50	93	0.240	2500	0.25	19	42	
			60	101	0.257	2700		17	44	
KA1238L1-1N	B, S		50	93	0.240	2500	0.22	17	42	
			60	92	0.185	2450		16	41	
KA1238H2-1N	B, S	220-240	50	97	0.284	2600	0.16	21	42	
			60	109	0.285	2900		18	44	
KA1238M2-1N	B, S		50	92	0.236	2450	0.12	20	41	
			60	95	0.219	2550		18	42	
KA1238L2-1N	B, S		50	80	0.138	2100	0.07	12	35	
			60	55	0.095	1500		11	27	
KA1238HD-1N	B, S	115/230	50	97	0.284	2600	0.30/0.16	21	42	
			60	109	0.285	2900		18	45	

Specifications subject to change without notice

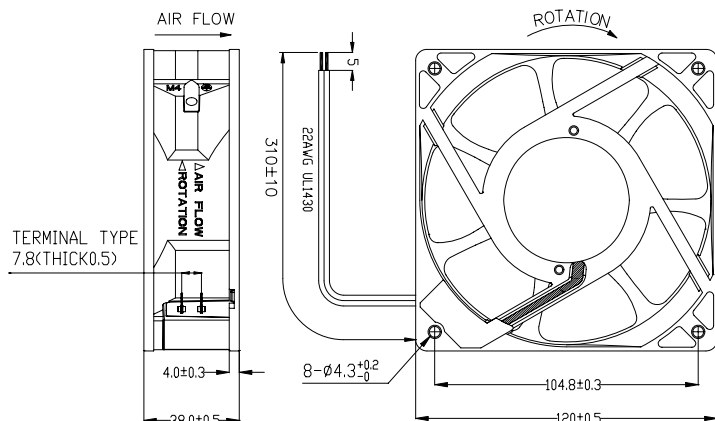
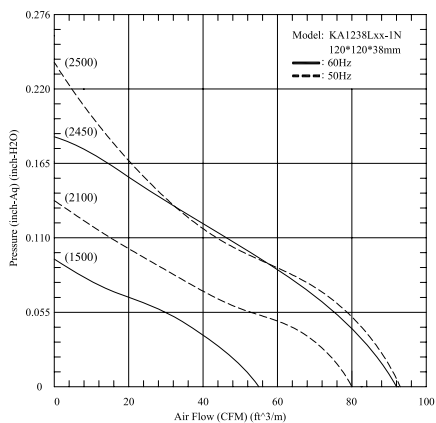
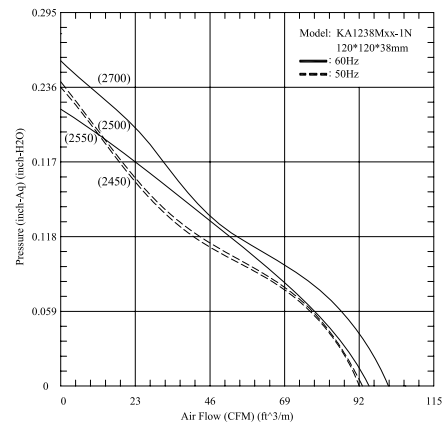
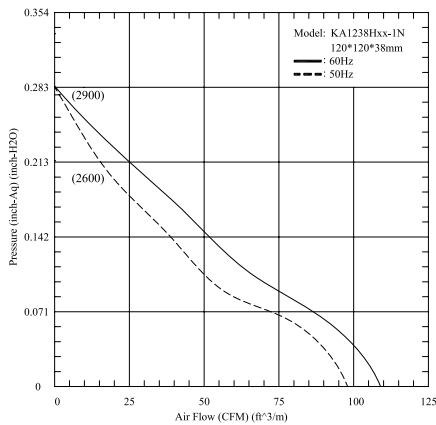

Part Number System

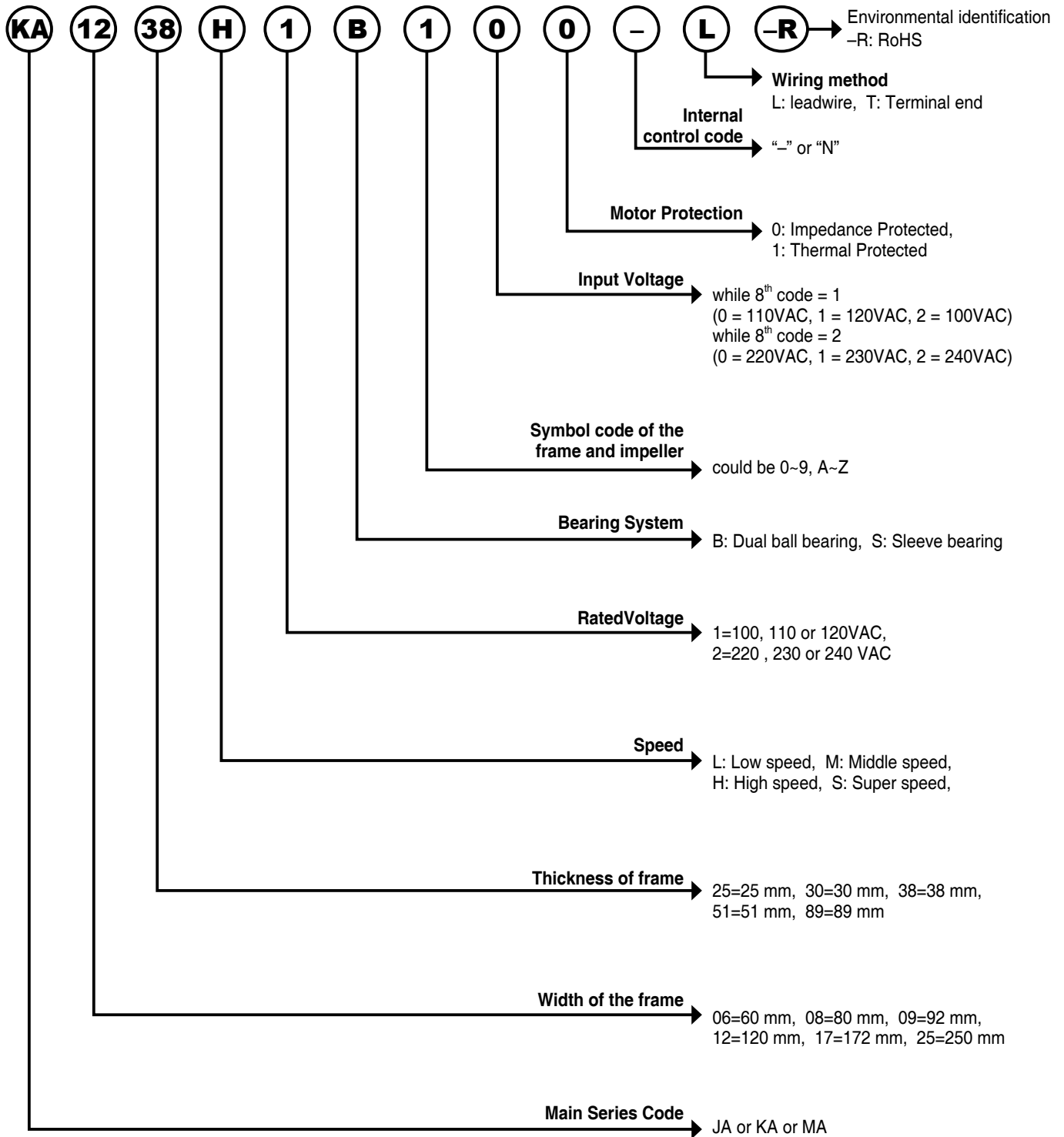

Reference List of Measure Unit

Air Flow Unit (風量單位)

CFM : Cubic Feet Per Minute (ft³/min ; 立方英尺/分)

CMM : Cubic Meter Per Minute (m³/min ; 立方公尺/分)

CMH : Cubic Meter Per Hour (m³/hr ; 立方公尺/小時)

Air Flow Unit Conversion (風量單位換算表)

CFM	CMM	CMH
1	0.0283	1.698
35.3	1	60
0.588	0.0167	1

Static Pressure Unit (靜壓單位)

Pa : Pascal (Pa = N/m² ; 牛頓/平方米)

mmAq : 1 mmAq = 1 mmH₂O

Static Pressure Unit Conversion (靜壓單位換算表)

Pa	mmH ₂ O	inch H ₂ O
1	0.10197	0.004017
9.80665	1	0.03939
249	25.4	1