

TYPE	Thread(D1)	Selection
D3A-SF-1L-M20	M20	
D3A-SF-1L-PG11	PG11	
D3A-SF-1L-PG13.5	PG13.5	

REVISION RECORD				
REV	ECN	DESCRIPTION	DRFT	DATE

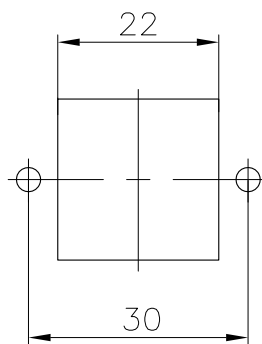

Panel cut out

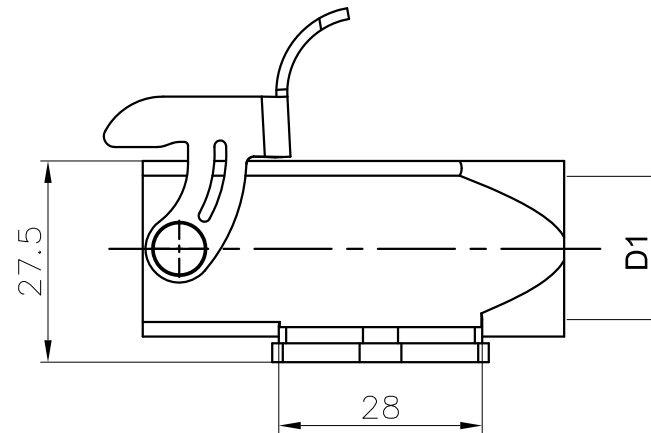
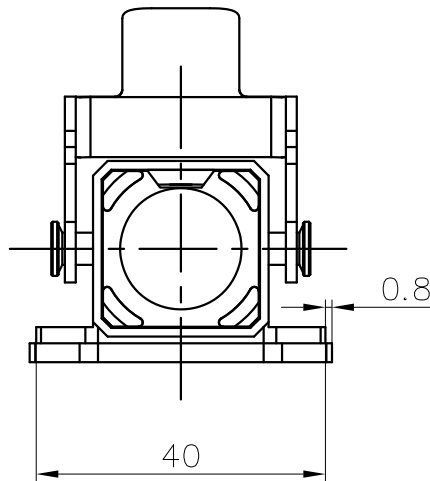
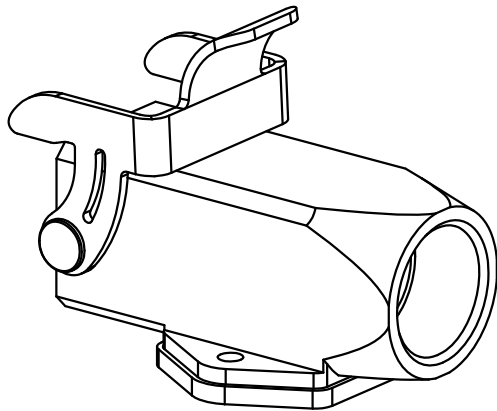
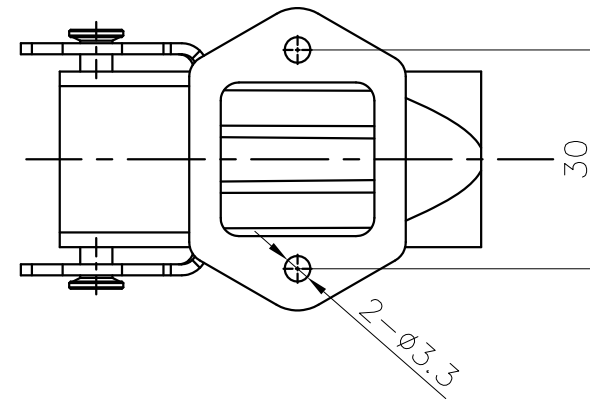

Housings Feature

1. Material: Zinc die-cast
2. Surface: Powder-coated
3. Color: grey (RAL 7037)
4. Material: Metal (Lever)
5. Sealing: NBR
6. Limiting temperatures: -40°C ~ +125°C
7. Flammability acc to UL94:V0
8. Degree of protection acc.to EN60529 for coupled connector :IP65
9. Rohs compliance

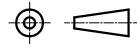
DETACHED LISTS	PART NO.:		 宁波高松电子有限公司 NINGBO DEGSON ELECTRICAL CO., LTD		
	APPD:	NAME:			
	CHKD:	D3A-SF-1L-M/PG			
	DRFT: Mr.yang2018.06.16	TITLE: CUSTOMER DRAWING	REV	DO-1	
 THIRD ANGLE PROJECTION		DRAWING NO.:	SHEET	1/1	
		MM (INCH)	DO NOT SCALE DRAWING	SCALE	1:1